



WHO WE ARE

Established in 2007, Advenser helps construction companies, general contractors, architects & engineers, integrate BIM into their projects seamlessly within their predefined timelines and budget, bridging the gap between concept & constructability.

Mission

To provide services to customers globally with cutting edge technologies and guaranteed cost savings.

Vision

To be recognized as a leading Business Process Outsourcing service provider delivering exemplary services.



OUR CLIENT BASE

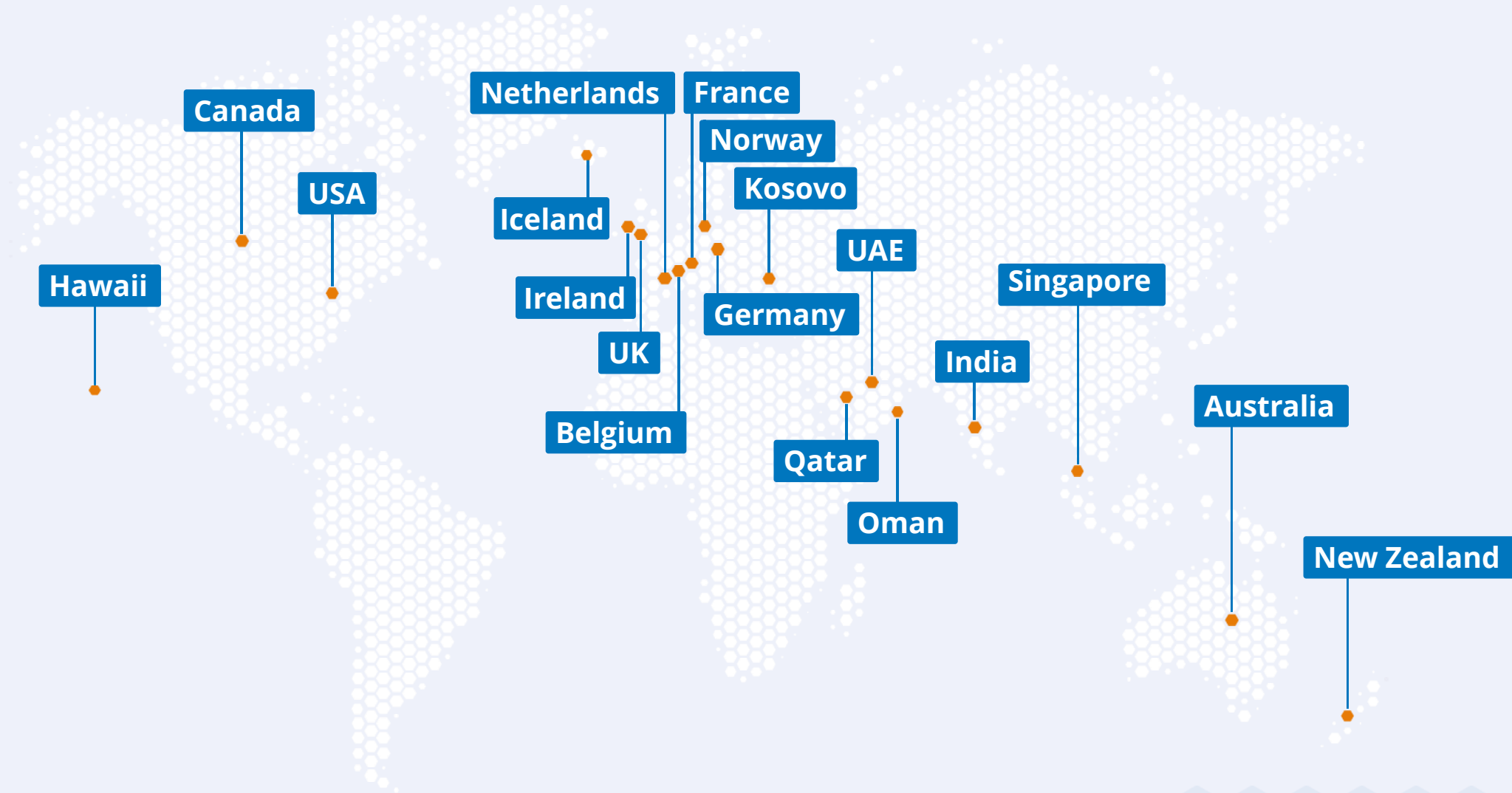

ADVENSER DIFFERENTIATORS



Comprehensive Set Of BIM Solutions



System Driven Best Project Practice



State-of-the-art Infrastructure



Refined Quality Assurance Procedure



Scalability & Flexibility Of Resources



Qualified & Specialized Resources



OUR ARCHITECTURAL BIM SERVICES



3D MODELING & BIM



SCAN TO BIM

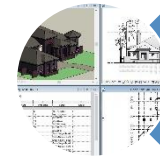

QUANTITY TAKE- OFF



COORDINATION WITH
STRUCTURE & MEP



BIM FOR INTERIOR DESIGN &
PROCUREMENT

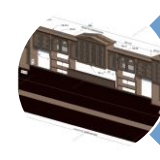

MILLWORK DETAILING

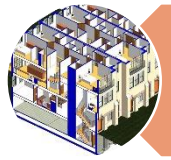

CONSTRUCTION
DOCUMENTATION



REVIT FAMILY CREATION



BIM FOR ENEGRY ANALYSIS

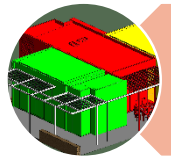

MODULAR BUILDING
MODELING

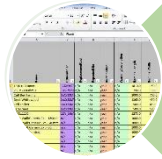

COBIE SERVICES FOR FACILITY
MANAGEMENT



SITE & LANDSCAPE
MODELING



UNDERSTANDING VARIOUS LOD's

Conceptual Design Stage

Deliverables: Mass model,
Conceptual model, Volumetric model

LOD 100

Design Development Stage

Deliverables: Progressive design model,
CD sets,. Energy analysis model

LOD 200

Construction Stage

Deliverables: CD sets,. Parametric
libraries, 3D Coordination

LOD 300

Fabrication Stage

Deliverables: Shop drawings,
Procurement Schedules

LOD 400

Operation Stage:

As-built model & drawings, Cobie
data for Facility Management

LOD 500



3D MODELING & BIM

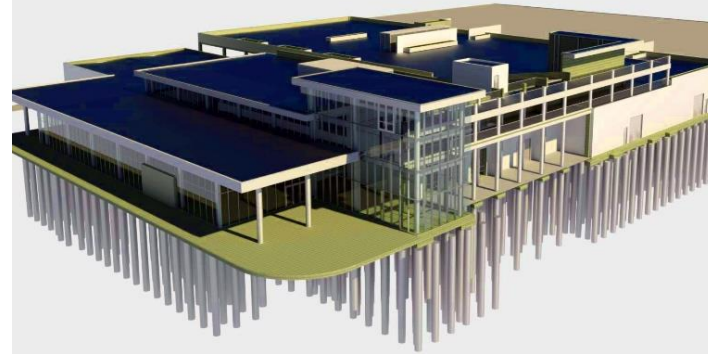

BIM has been a major driver in the transformation of architectural processes through the intelligent 3D software that allows architects to envisage what a completed design will look like in detail ahead of time.

Across all stages of planning, designing, constructing and managing buildings, we help increase project cycle efficiency and cross-discipline integration.



COORDINATION WITH OTHER SERVICES

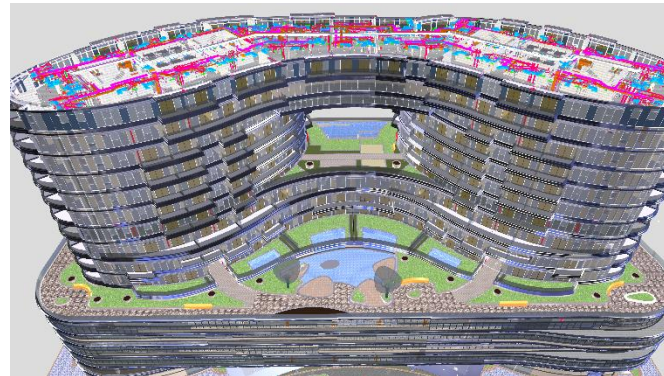
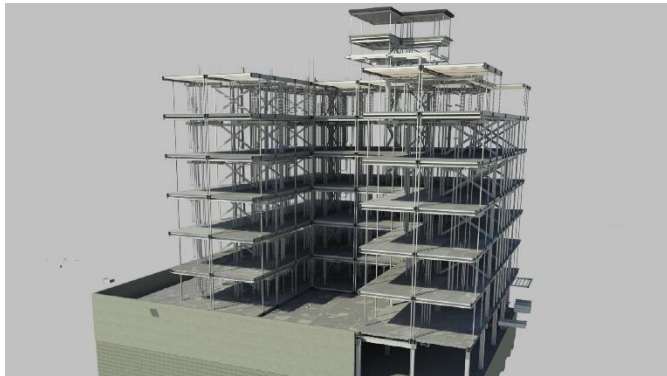
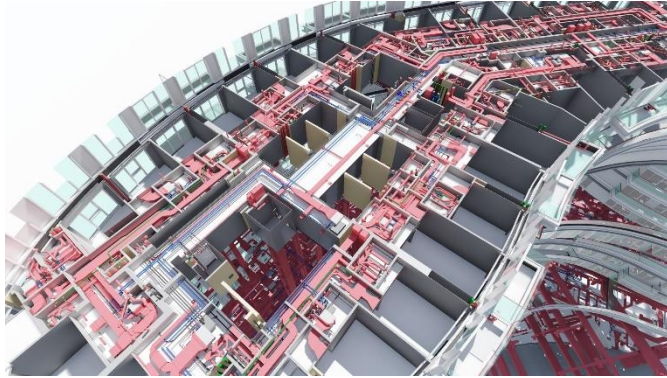

Seamless coordination of structural & MEP elements with Architecture allowing all systems to work in perfect synchronization & at the same time maintain the design intent.

Generation of Clash Reports, Resolution of Clashes and conducting BIM Coordination Meetings with contractors and other stake holders. Are one of the core services we offer for all trades.



CONSTRUCTION DOCUMENTATION

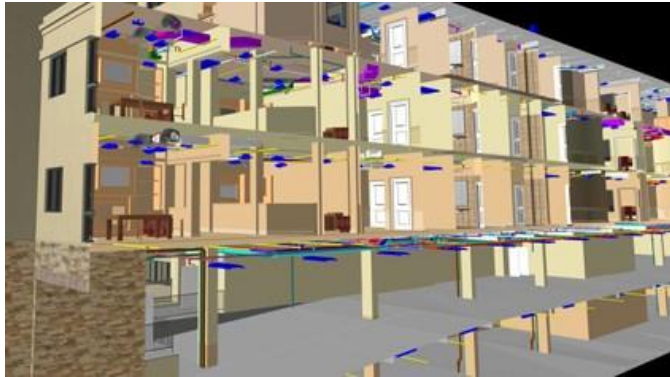

Architectural Construction drawings are generated during the design development stage after the planning drawings are approved, & include details such as floor plans, elevations, sections, reflected ceiling, roof & site plan, detail sheets, GA & assembly drawings.

The comprehensive BIM models we produce in consultation with the client are embedded with necessary information, parameters and specifics to generate accurate construction drawings & documentation.



BIM FOR MODULAR & PREFABRICATED CONSTRUCTION

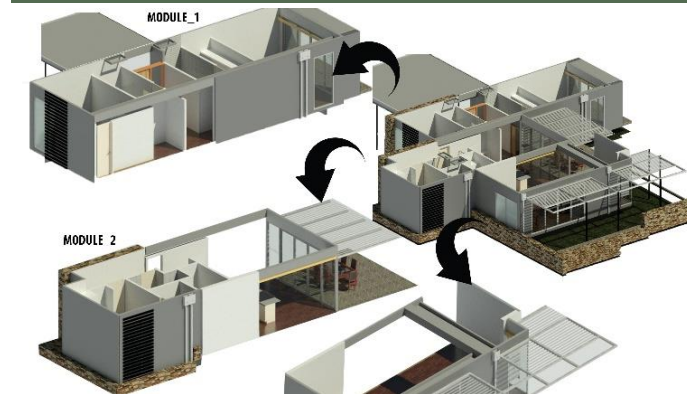
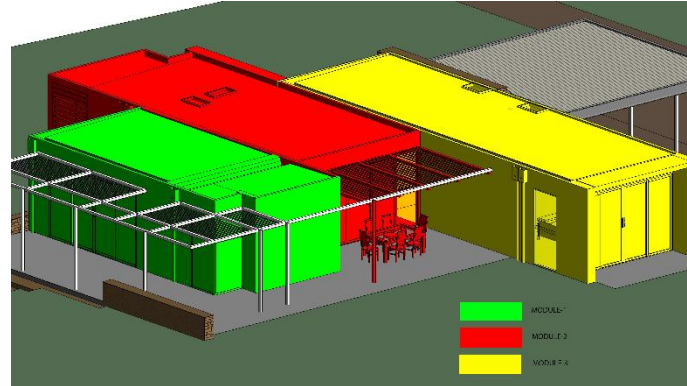

BIM acts as the integration tool for individual modules of a prefabricated modular construction. It allows a perfect and seamless fitting of individual embedded components in the building

We create 3D BIM modules for visualization of individual modules & the entire building integrating all modules. The accurate drawings generated from the models give sub-contractors precise measurements for the units to be prefabricated off-site.



SCAN TO BIM



A physical space or site is scanned by a 3d laser scanner to create an accurate digital representation of it. This representation can then be used for designing, assessing progress or evaluating option.



Scanned pointcloud file of an existing building is exported to a BIM platform by our experts to develop an accurate AS-Built model depicting the plumbing, walls, slabs, roof planes & terrains.



BIM FOR INTERIOR DESIGN & PROCUREMENT



Every object placed in the model has parameters, such as model number and cost, from which the schedules pull their information. Designers can start scheduling furniture and equipment the moment an object is added into the model.

Our engineers help interior designers leverage the benefits of BIM in architectural and interior design aspects by applying intelligent modeling to the finishes, the fixtures, the area requirements and the furniture schedules.



REVIT FAMILIES / PARAMETRIC LIBRARIES

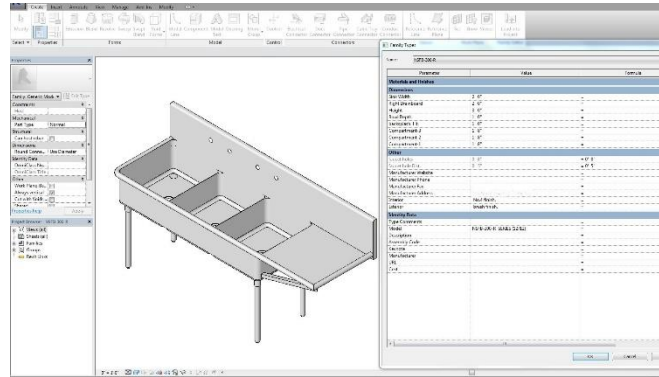
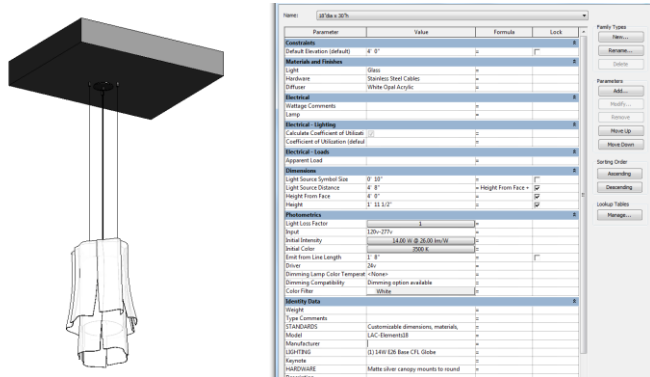

BIM objects are a family of intelligent virtual 3D objects that provide detailed information of a product or component about its physical characteristics such as its geometry & visual graphical representation.

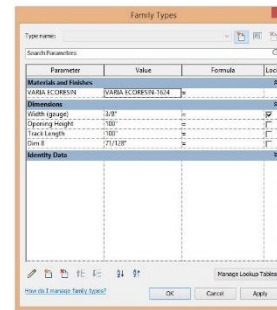
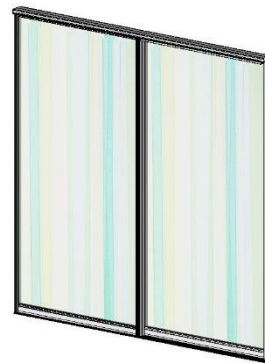
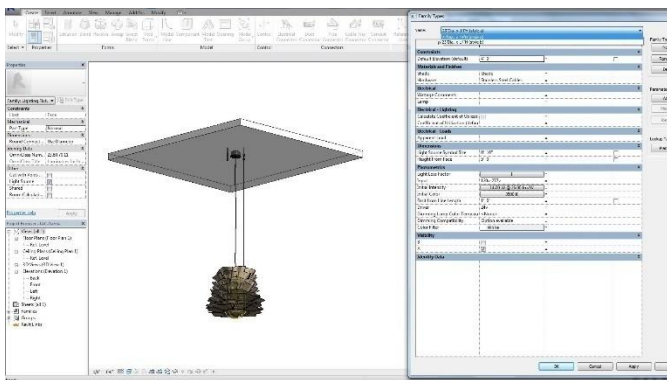

We provide parametric & non-parametric creation services for manufacturers, fabricators, architects & engineers for their product model catalogs, which can be downloaded directly by their customers from their websites..



COBIE DATA FOR FACILITY MANAGEMENT

Family:	ST-ICL-CN	Load...
Type:	TC10-FN	Duplicate... Rename...
Type Parameters		
Parameter	Value	
Structural		
Section Shape	Not Defined	
Dimensions		
x1	895.000	
x2	100.000	
x3	0.000	
y1	0.000	
y2	1100.000	
b	2000.000	
h	1678.000	
y3	203.951	
Identity Data		
Type Image		
Keynote		
Model		
Manufacturer		
Type Comments		
URL		
Description		
Assembly Code		
Cost		
Assembly Description		
Type Mark		
OmniClass Number	23.25.30.11.14.11	
OmniClass Title	Columns	
Code Name		

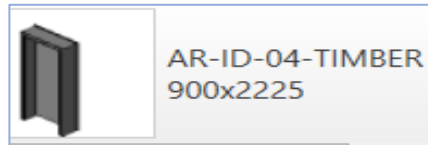

Family:	AR-ID-04-TIMBER	Load...
Type:	900x2225	Duplicate... Rename...
Type Parameters		
Parameter	Value	
Construction		
Function	Interior	
No.Of.Leaf	1	
Wall Closure	By host	
Construction Type		
Materials and Finishes		
Architraves	Architraves	
DoorFrame	DoorFrame	
NonFireRatedDoorShutter	DoorShutter	
Dimensions		
Angle	90.000°	
Height	2150.0	
StructuralHeight	2225.0	
StructuralWidth	900.0	
SwingWidth	770.0	
Width	750.0	
Rough Width		
Rough Height		
Thickness	45.0	
Analytical Properties		
Analytic Construction	<None>	
Visual Light Transmittance		
Solar Heat Gain Coefficient		
Thermal Resistance (R)		
Heat Transfer Coefficient (U)		

Construction Operations Building Information Exchange (COBie) is a non-proprietary data format for the publication of a subset of building information models (BIM) focused on delivering asset data as distinct from geometric information

Advenser follows COBie process for managing FM model incorporating information such as the make, cost, warranty, contact records & required product specifications.



SITE & LANDSCAPE MODELING

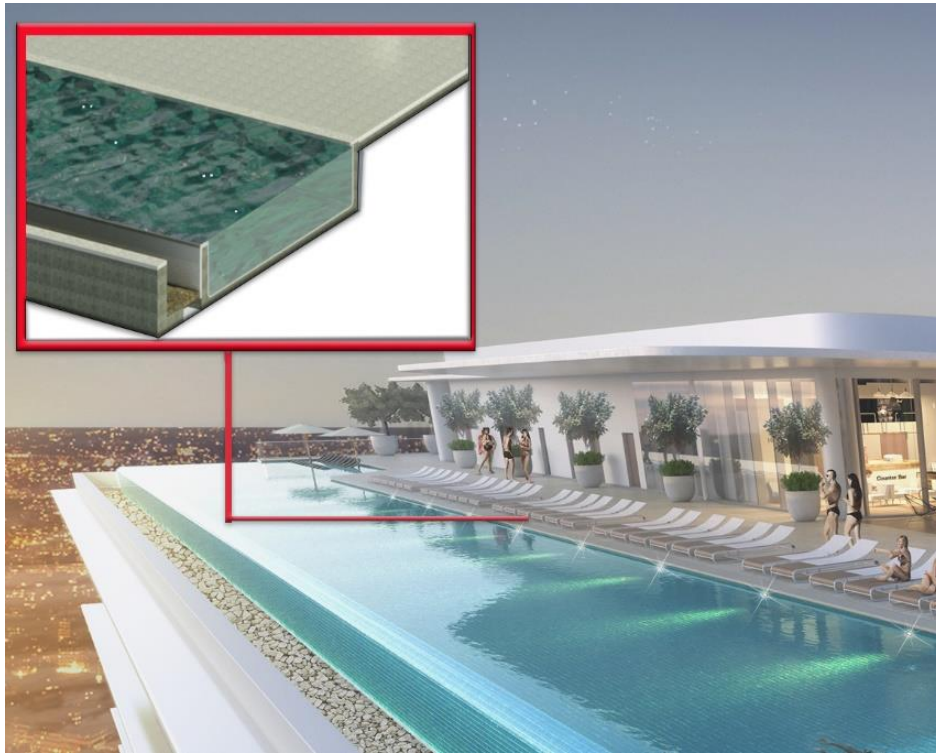

The main benefit of using BIM for site and landscape modeling lies not in its modeling prowess, but rather in the ways it enables communication among various designers

Utilizing BIM we help landscape architects to address details and construction issues in the early stages of project development



QUANTITY TAKE-OFF

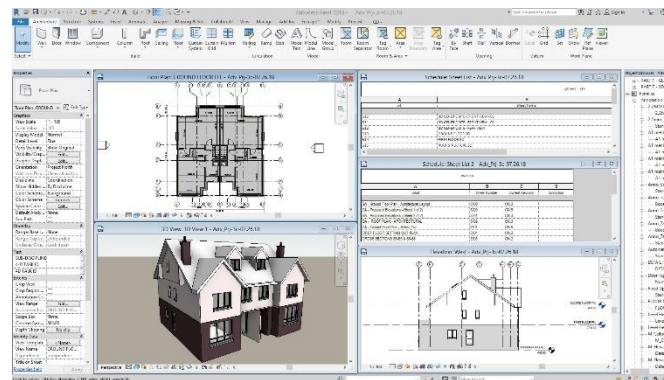
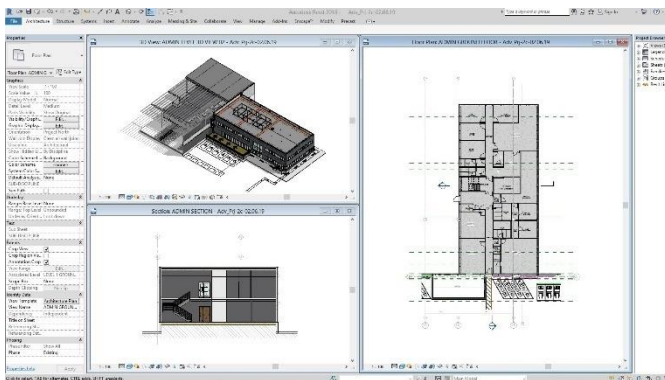
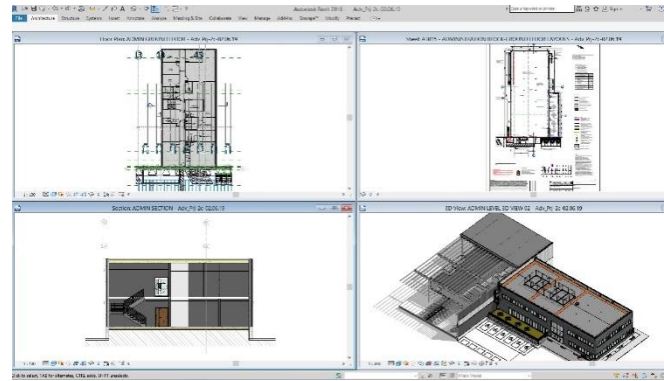
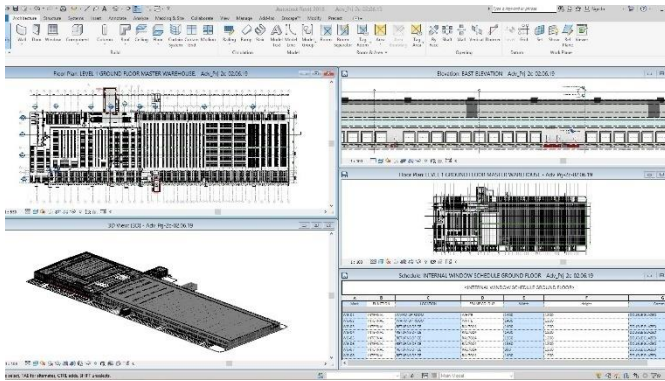

BIM enables extraction of measurements and material quantities straight from models that help material procurement

We can generate a list of all raw materials, parts, intermediates, sub-assemblies, etc., (with their quantities and description) required to construct, overhaul, or repair something



BIM FOR ENERGY ANALYSIS

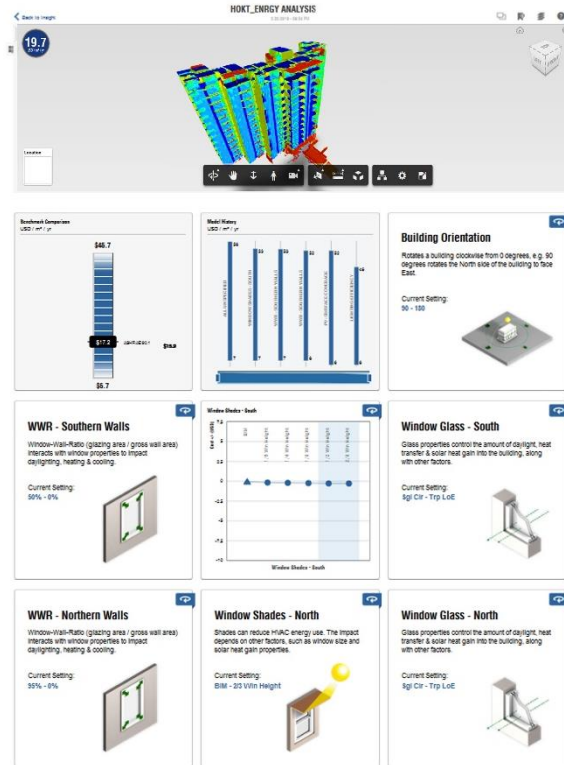
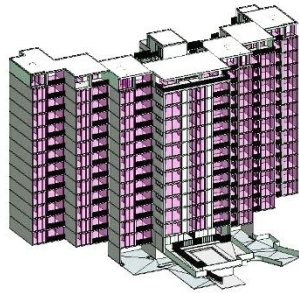
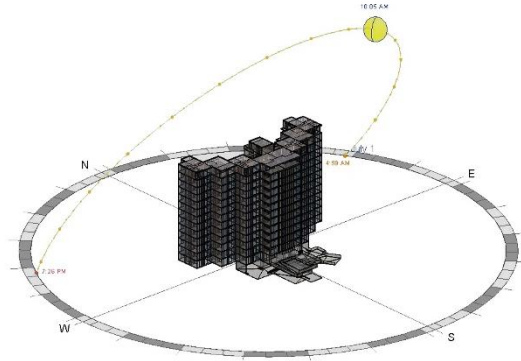

Energy modeling happens throughout the design process from concept through post-construction.

Advenser delivers models for energy analysis at the concept stage which has all spaces clearly defined and the model will be ready to be exported to gbXML format.



MILLWORK DETAILING

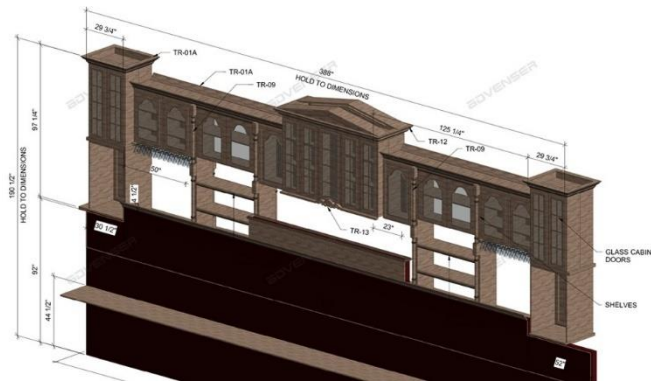
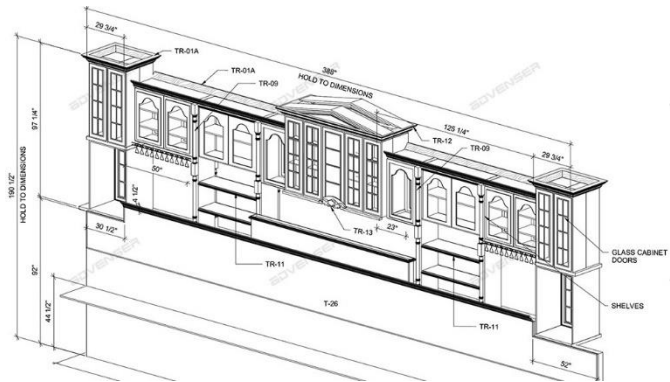
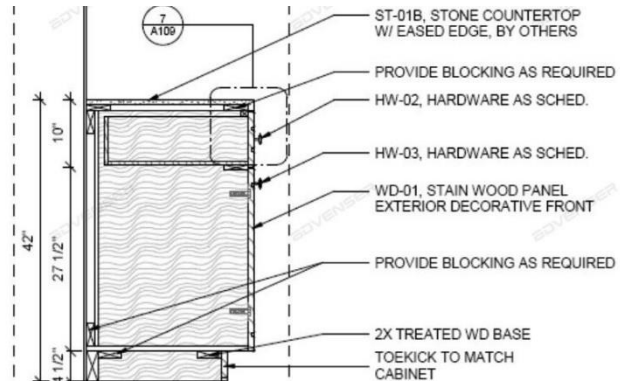
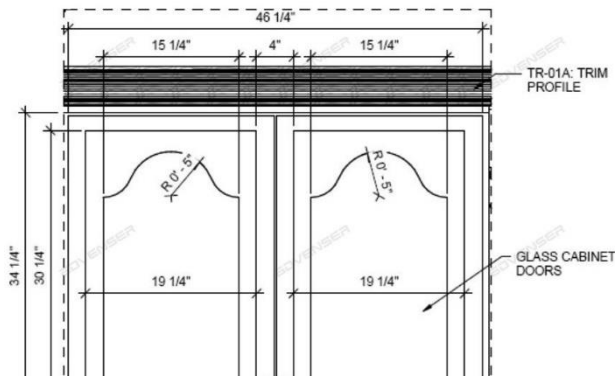

From a simple cabinet to a luxurious star hotel lobby, we offer you a one-stop solution to your millwork shop drawing needs.

We have the expertise to produce essential plans, floor plans, elevations, section details, finish and hardware schedules for all sorts of millwork design.



BIM CONSULTING SERVICES

Since 2007, we have been assisting construction companies, general & specialty contractors in their migration to BIM from CAD. We act as a strategic BIM partner to the client educating and training them for seamless migration from CAD drafting to BIM implementation.

BIM MODEL AUDIT

OFFSHORE BIM TEAM

BIM IMPLEMENTATION PLANNING

BIM TRAINING

ON-SITE BIM SUPPORT

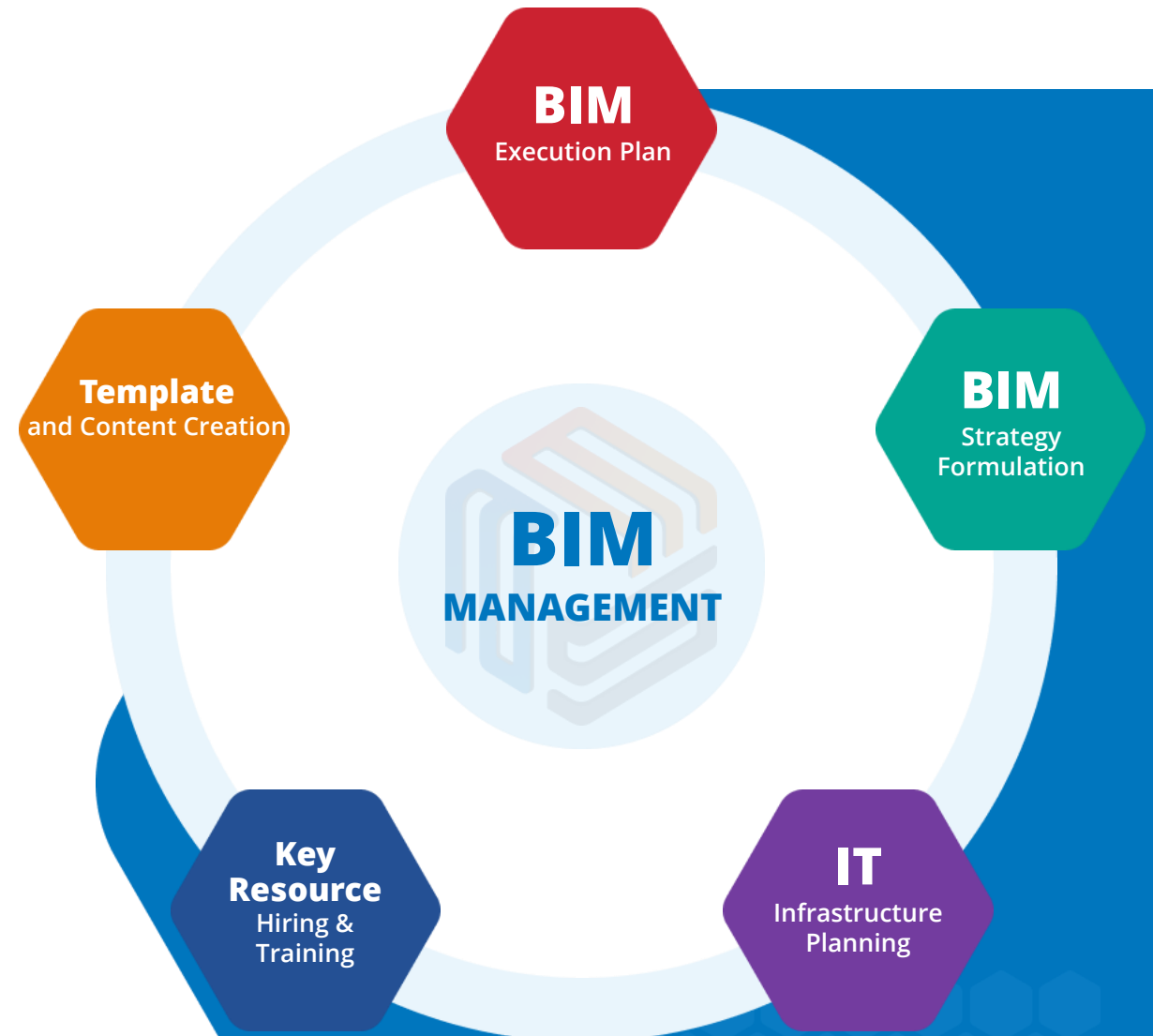

OUR DETAILING PROCEDURE

OUR APPROACH

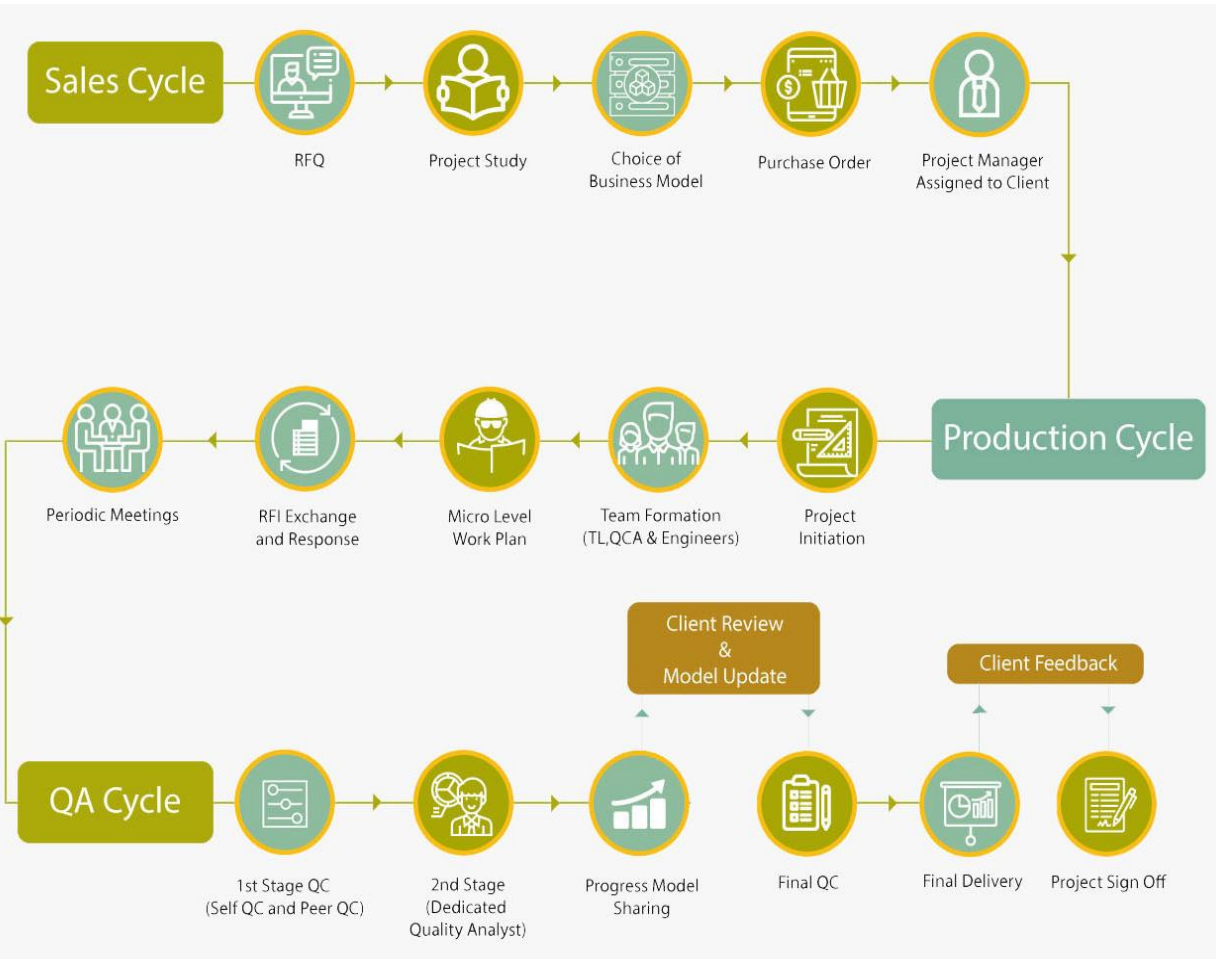

Understanding Client Requirements: With every client, we understand that a different approach may need to be employed with every project, bringing a new set of skills and technology to the table. We devote the time needed to study the objective of the project.

Delivering Solutions: To achieve the goals of the project, our engineers adopt the most appropriate methods, outdoing themselves. Our work is to follow a system driven process incorporating the latest methods in the BIM industry which ensures projects are delivered on time and are nothing short of the highest quality..

Constant Improvement: The engineering team, led by highly capable and seasoned project managers tirelessly learn, research and update themselves to meet the ever-changing and dynamic demands of the AEC industry. Systematic knowledge sharing and perfection of the work process is an ongoing process in Advenser. With every project, we see to it that we always make room for innovation.

Our Promise: Client satisfaction is a promise we assure and we measure our successes on par with that of our client's. We take pride in our past glory & achievements but at the same time strive to make them nothing more than mere milestones in our pursuit of excellence.



TEAM PROFICIENCY & SOFTWARE PROFICIENCY

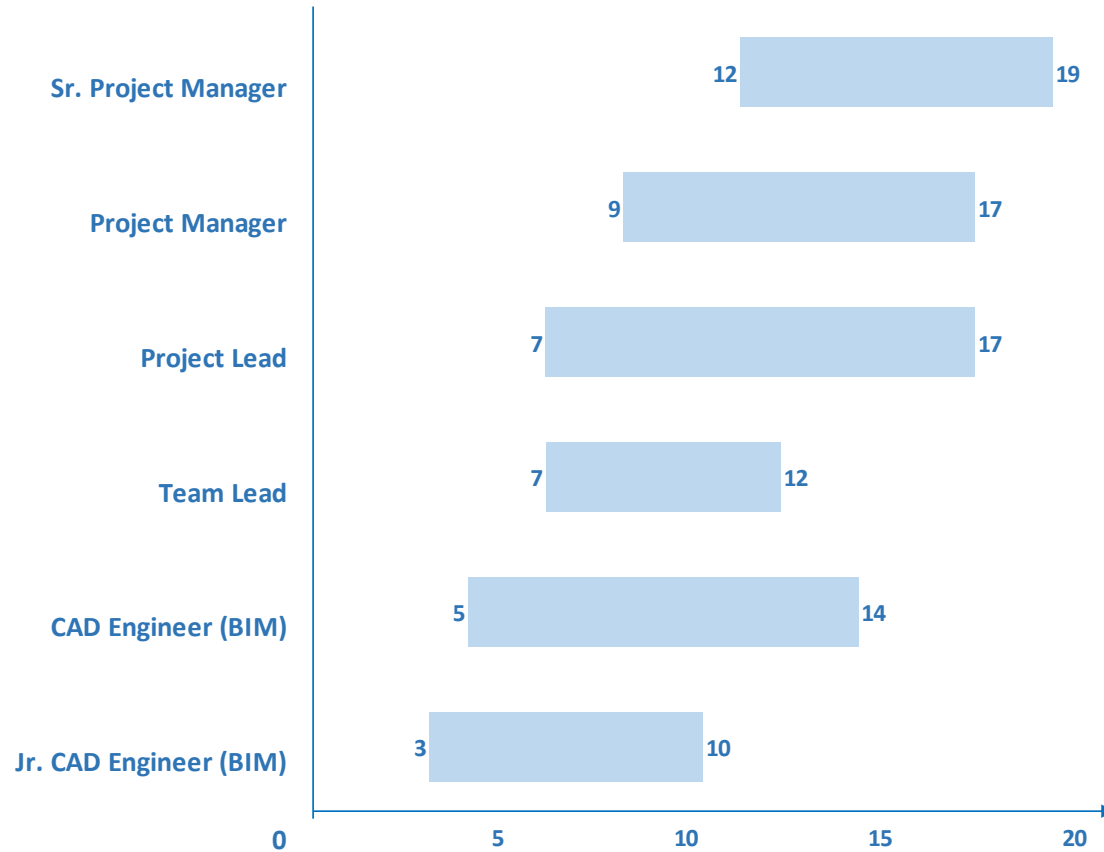

Revit Suite



BIM 360



AutoCAD



LogiKal



AutoCAD 360 PRO



Autodesk Inventor



Navisworks Manage



MagiCAD



ReCapture



Civil 3D



Building Data



Construction Cloud



FEATURED PROJECTS

Imperial Avenue, UAE



FEATURED PROJECTS

Perth Police Station, WA, Australia



FEATURED PROJECTS

Kamehameha Highway Metro Stations, HI, USA

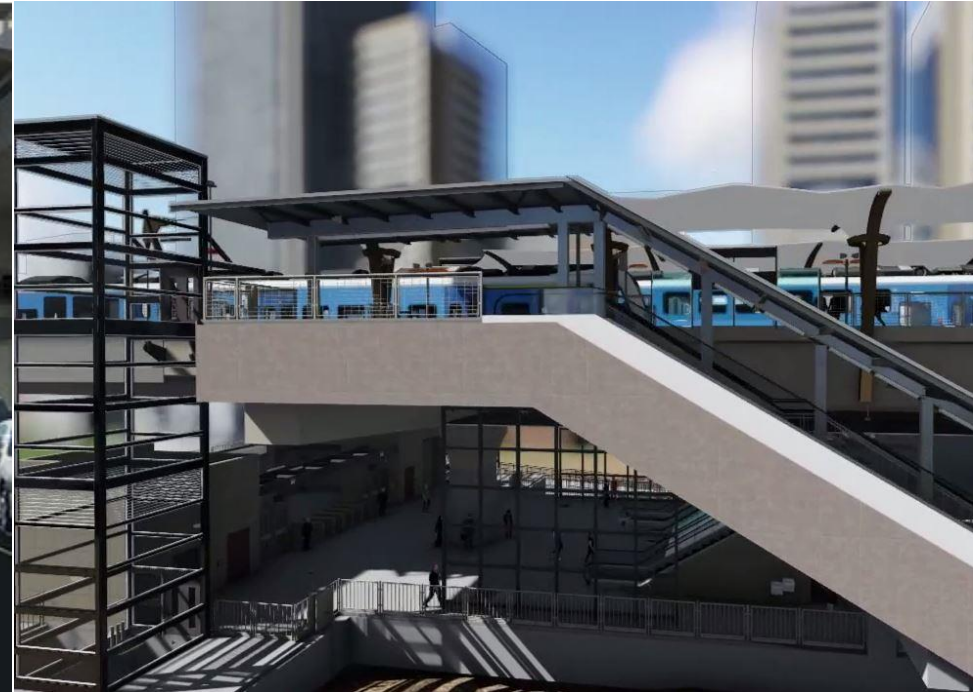
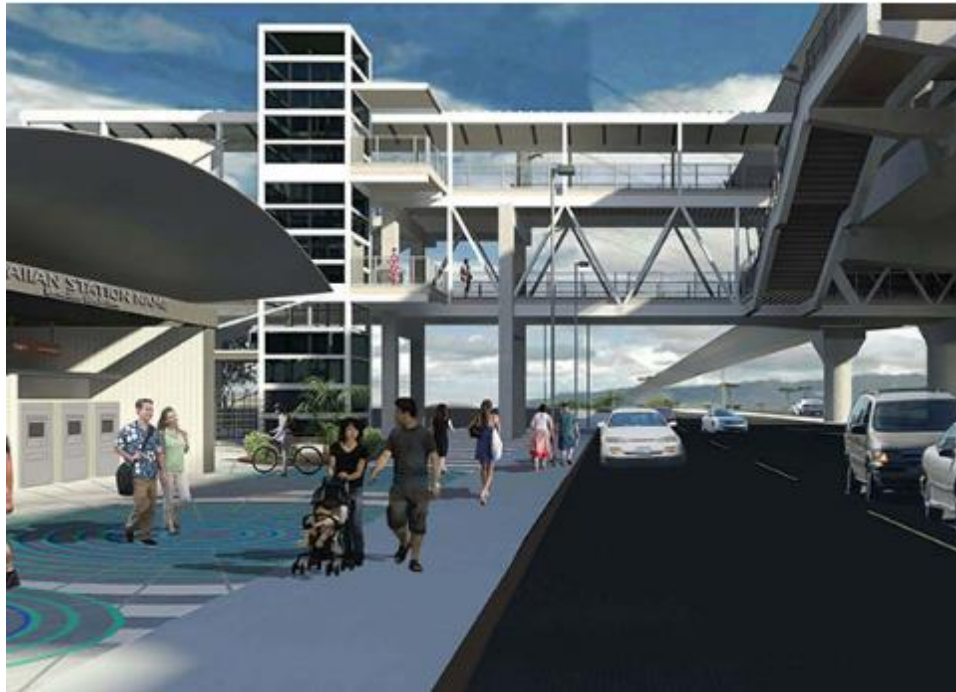

FEATURED PROJECTS

Montrose Apartment Towers, Dubai



FEATURED PROJECTS

Ivy Quad condominiums, IN



FEATURED PROJECTS

Ivy Quad condominiums, IN

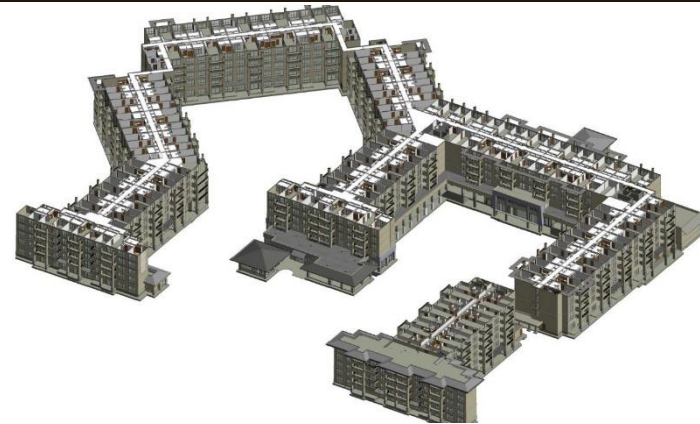

FEATURED PROJECTS

Ko Olina Beach Villas, HI, USA



FEATURED PROJECTS

Movenpick Hotel, Colombo, Sri Lanka



FEATURED PROJECTS

7001 Arlington Road, MD, USA



CONTACT US



Advenser Technology Services, Inc.

Five Neshaminy Interplex, STE 205
Trevose, PA 19053, USA

Phone: +1 (215) 791 7955



Advenser LLC

Five Neshaminy Interplex, STE 205
Trevose, PA 19053, USA

Phone: +1 (215) 934 2868



Advenser Engineering Services Pvt. Ltd.

43 A, E block, 4F CSEZ, Kakkanad
Kochi, Kerala, India. Pin 682 037

Phone: +91 484 298 8448



Advenser Engineering Systems LLC

P.O. Box No: 118901,
Dubai, UAE

Phone: +971 50 237 7430



Advenser Engineering Services Pty. Ltd.

Unit 26, 14 Jubilee Avenue
Warriewood NSW 2102, Australia

Phone: +61 363 877 090



Advenser Engineering Services Pvt. Ltd.

403, 4F, Lulu Cyber Tower 1, Infopark
Kochi, Kerala, India. Pin 682 042

Phone: +91 484 404 0708



www.advenser.com



info@advenser.com

THANK YOU

